



## **Citroen C5 estate** **Model year up to 18 February 2002**

### **Engine will not start**

If there are complaints about the above-mentioned fault, the cause could be a flat battery. This condition arises increasingly if the vehicle has been at a standstill for a longer period of time. The battery is discharged due to excessive quiescent current. The increased quiescent current may arise due to a permanently illuminating LED. This LED is located in the suspension-height switch, which is located in the rear right-hand area of the boot. The power consumption due to permanent supply of the LED is 20 mA. In this case, the earth cable of the LED must be cut. As the cover of the switch is non-transparent, illumination is superfluous.

To do this, proceed as follows:

- Remove the switch for the suspension height (on the right, in the boot, see Fig. 1). When removing the switch, care and patience are required due to the fastening.
- Remove the plug from the switch.
- Press down the locking tab of the earth cable 7749 (see Fig. 2) and pull the socket contact out of the plug housing.
- Cut off and insulate the earth cable where the wiring harness exits.
- Refit all removed parts in reverse order.

**Bulletin**

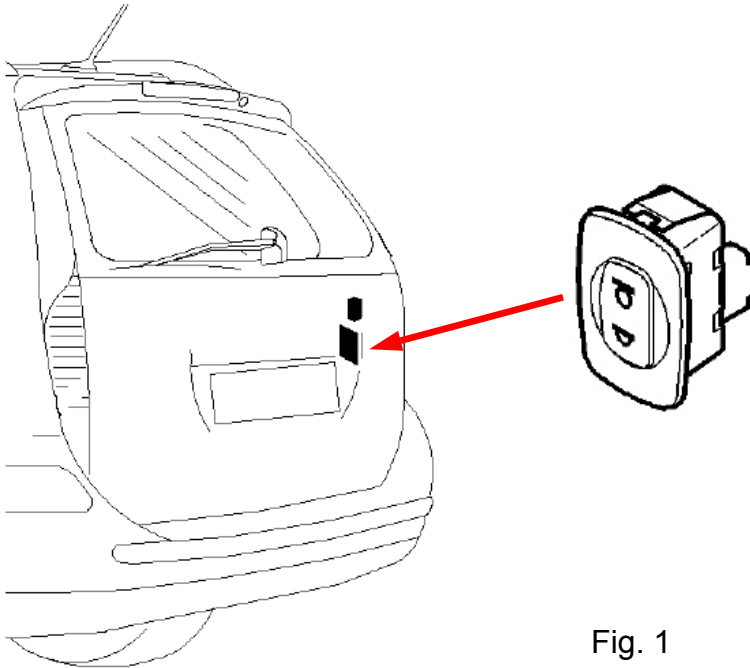

Fig. 1

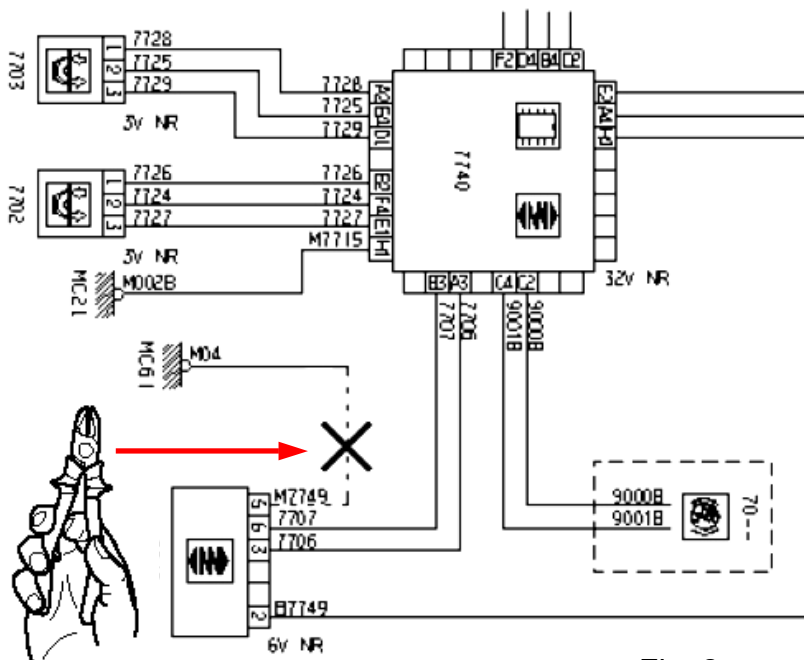

Fig. 2