



Ford Mondeo 2001 Models built up to 01/2002

Whistling noise from the heating system.

If there are faults about the above-mentioned fault, a possible cause could be an air gap between the two housing sections of the heat exchanger/evaporator housing. The noise is most clearly audible at fan speed 1 and 2 (2nd to 3rd fan speed graduation on electronic air conditioning) and disappears if the fan is switched off.

To eliminate the noise, the air gap at the heat exchanger/evaporator housing must be sealed. The area to be sealed is shown in the illustration below. In order to carry out the repair, the housing must be dismantled.

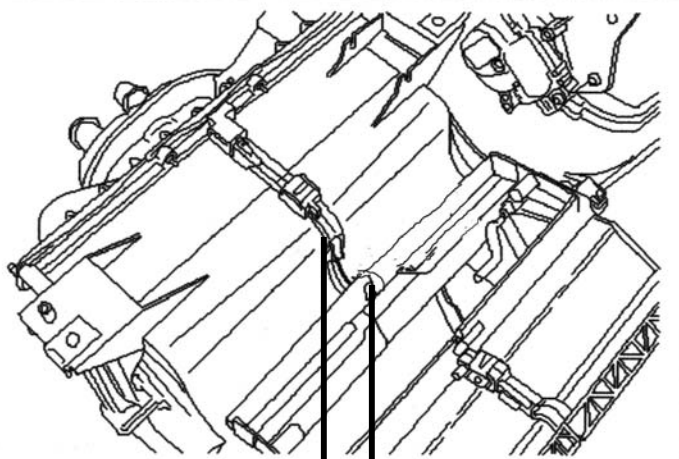

→ ← Area to be sealed (approx. 7 – 8 cm)

Bulletin