

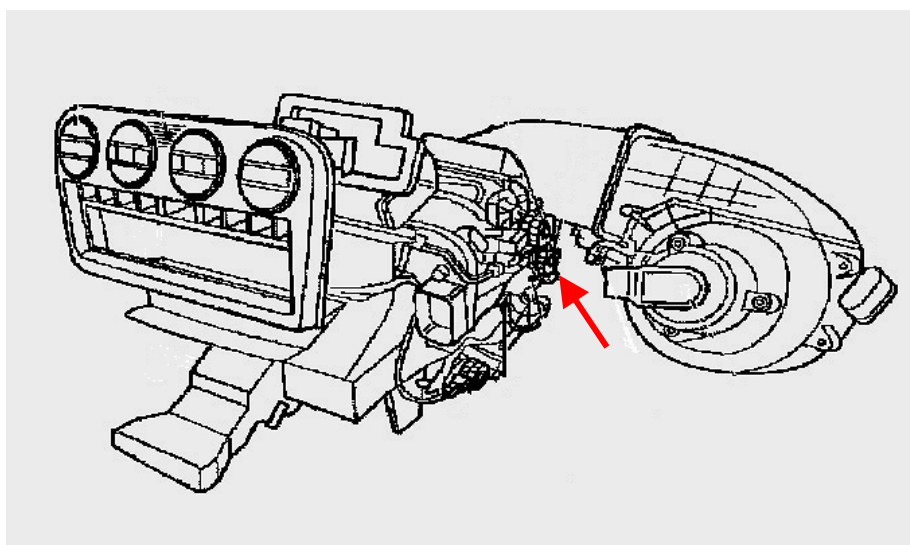

## **Opel Omega B Model year: 1996 With automatic air conditioner**

### **Front window fogs up**

If the windscreen fogs up on the above-mentioned vehicles after the engine has been started and the air conditioner is switched on, this can be connected to the actuator motor of the defroster flap (see drawing). If this flap does not close properly, the result can be fogging of the windscreen. A diagnosis tester can be used to attempt to remedy the situation by basic setting of the actuator motors. If necessary, the actuator motor must be replaced. From vehicle identification no. 1024050 onwards modified actuator motors were installed in the factory.



**Bulletin**