

professional

Diamond-coated crankshaft washer

to fit

Audi A6

VW Crafter

VW Transporter T4

Volvo 850, S70, S80, V70 I, V70 II

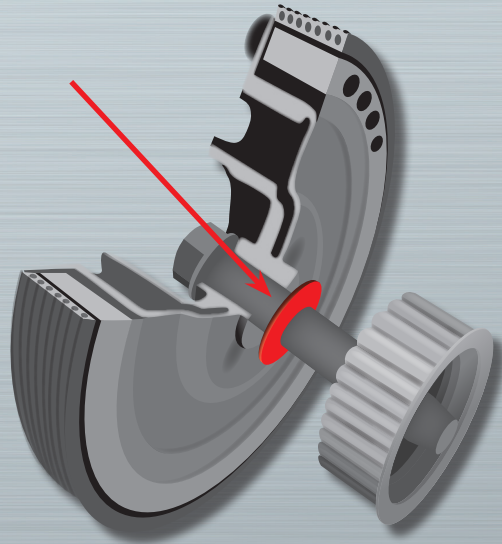

PROBLEM

Despite replacing the belt pulley, it still slips.

CAUSE

The diamond-coated crankshaft washer was not replaced when the belt pulley was replaced.

SOLUTION

The diamond-coated crankshaft washer sits between the timing-belt pulley and the TVD crankshaft pulley and assists with the smooth transmission of drive. If a diamond-coated crankshaft washer is not used, even if the crankshaft gear bolt is tightened to specification, this cannot prevent the TVD crankshaft pulley from slipping, as it does not provide the same continuous transmission of drive as the (replaced) diamond-coated crankshaft washer does.

Therefore, it is absolutely essential to use, and, if necessary, replace a diamond-coated crankshaft washer.

SWAG's crankshaft washer has a high-quality nickel-diamond coating which prevents the belt pulley from spinning. In addition, optimum power transmission is guaranteed.

In order to avoid costly consequential damage, the SWAG vibration damper repair kits for Volvo 850, S70, S80, V70 I, V70 II, VW Crafter/T4 and Audi A6 include the diamond-coated crankshaft washer.



Diamond-coated
crankshaft washer

SWAG no. 30 93 1815

Ref. no. 074 105 193

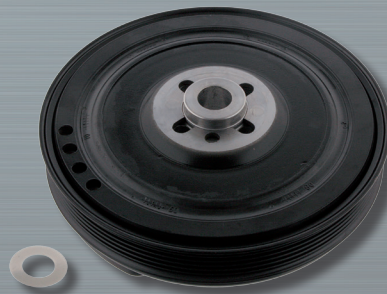

TVD crankshaft
pulley rep. kit

SWAG no. 30 93 1858

Ref. no. 074 105 251 C S1

SWAG no. 30 93 1857

Ref. no. 074 105 251 J S1